

AUTOPEDED^(TM)/ MODEL-10 OPERATOR INSTALLATION

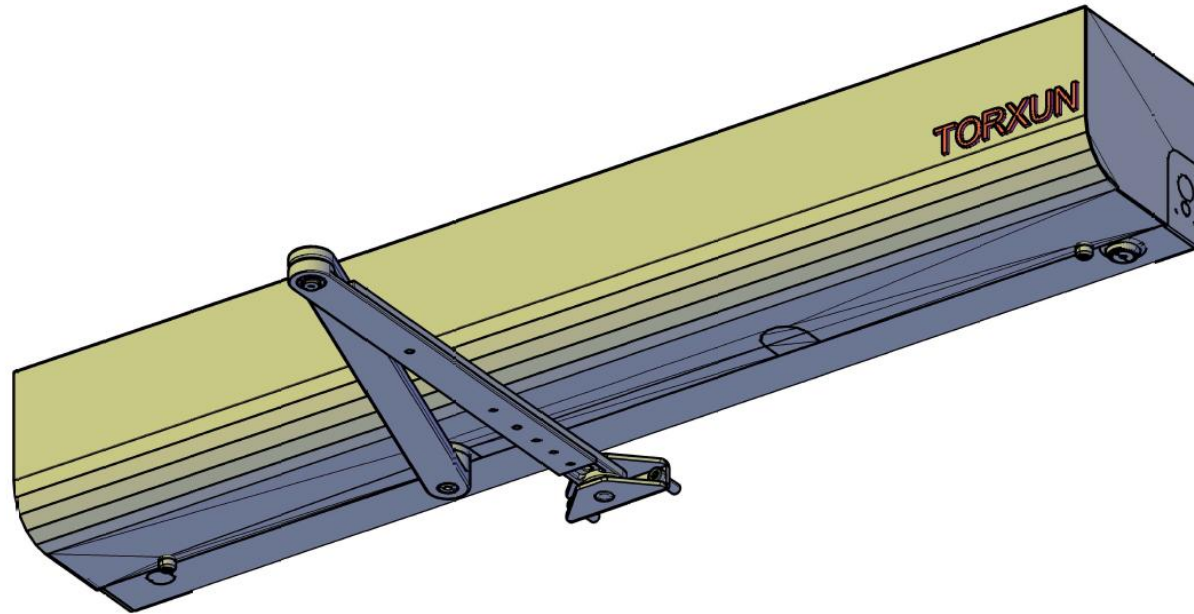

©2021

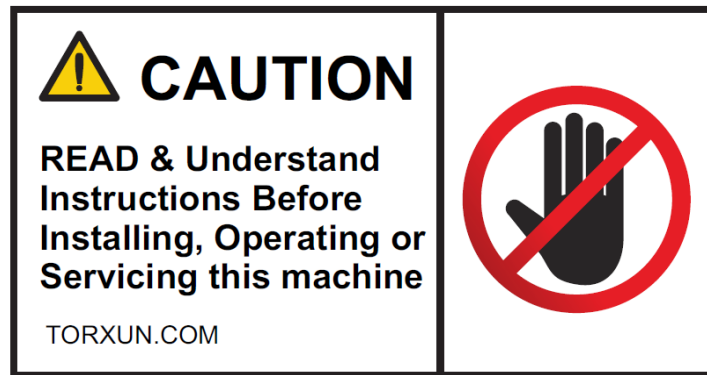

TORXUN reserves the right to make changes in the products described in this manual without notice and without obligation of TORXUN to notify any persons of any such revisions or changes. Additionally, TORXUN makes no representations or warranties with respect to this manual.

This manual is copyrighted 2021 TORXUN Vehicle Access Systems, all rights reserved.

No portion of this manual may be copied, reproduced, translated, or reduced to any electronic medium without prior written consent from TORXUN.

INTRODUCTION

Welcome--thank you for your purchase! Our commitment to quality and innovation will become evident as you become familiar with the features, performance and easy installation of this expertly engineered Model10/AUTOPED heavy duty pedestrian and small vehicle swing door/gate operator.

Some of its features are:

- Fully outdoor rated
- Built for continuous, heavy duty use for gates up to 250 lbs and 55" wide
- UL 325 listed and Designed to meet or exceed ANSI 156.19 low energy operated swinging doors standards
- A single model works for left and right-hand door/gates and push and pull applications

Installers

I love you folks! I've been installing gate systems for decades. We've organized these instructions to keep things simple.

The standard install are in this short Installation Manual. When you need to perform more complex installations and/or programming, refer to the Appendix. Throughout, we'll point you right to the page to which you need to refer.

Be safe! Think about your own safety during the installation. Also think about the safety of the public who will be using this automated gate for years to come. You **NEED** to be familiar with ANSI 156.19 standards. It is your responsibility to install and program the AutoPed to comply with these standards which include the velocity of the gate-in-motion, the force of the gate panel and the safety/warning labels. This manual will remind you of these responsibilities, but at the end of the day, you are the one in the field and are responsible for the publics' safety! Options --some installations will require optional parts that you will need to order from your distributor to complete your installation. Refer to the Appendix manual under **AUTOPED Operator Parts and Components** (pg. A-5) before you head out to install to confirm you have what you need.

Owner/User

You are in for a treat! This operator is going to bring the satisfaction of automation to your property making residents and users happy that life has gotten just a little easier. Safety first! Please make sure that someone is responsible for daily checks of the gate system.

For service, use only qualified and trained technicians.

I want you to love this Model 10 Operator. I've been in this industry since 1976 and have never stopped trying to make products better. So let me know what you'd like improved....AND what you appreciate.



A handwritten signature in black ink, appearing to read 'Art Hird'.

Art Hird, President

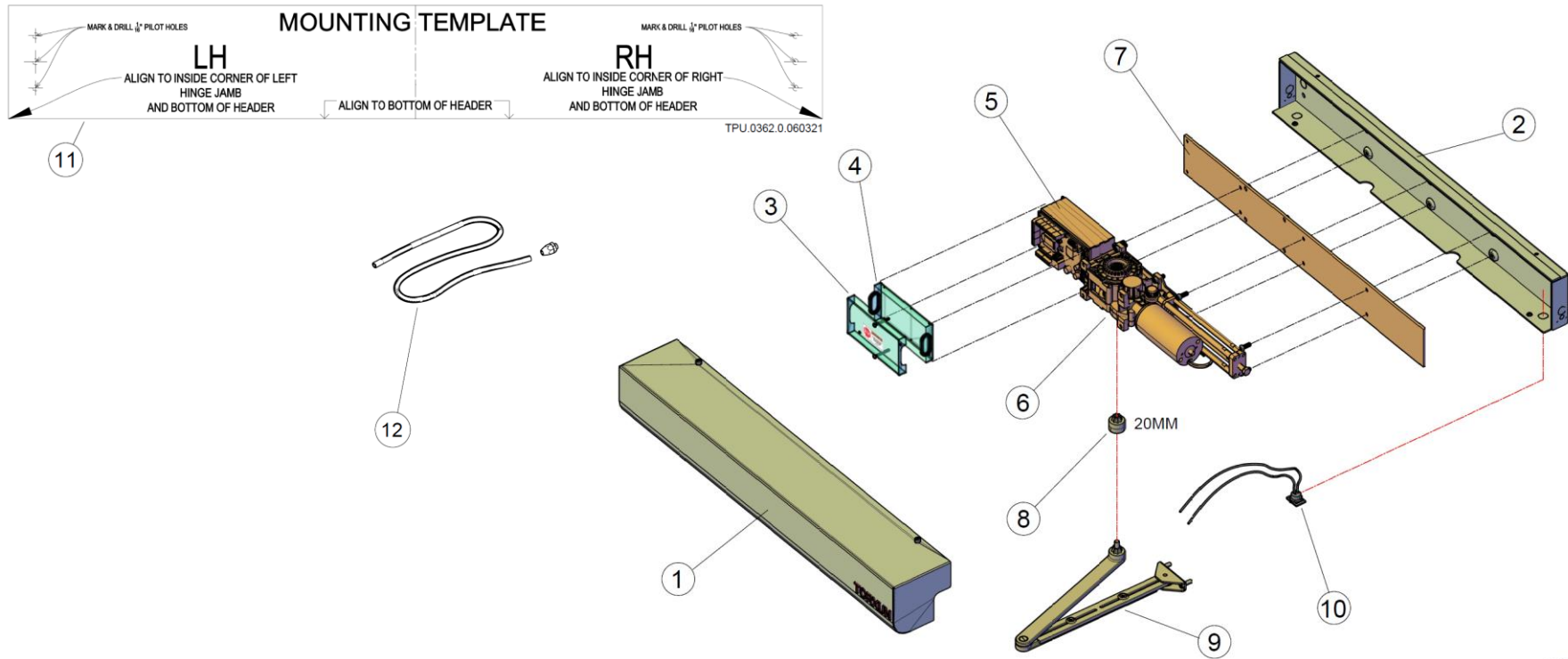

TABLE OF CONTENTS

INTRODUCTION	3
WELCOME LETTER FROM MR. ART HIRD (PRESIDENT, TORXUN VEHICLE ACCESS TECHNOLOGIES).....	4
AUTOPED PARTS AND COMPONENTS.....	7
PARTS/COMPONENTS EXPLODED VIEW (WHAT'S IN THE BOX)	7
PARTS/COMPONENT LIST AND DESCRIPTIONS	7
SECTION I. INSTALLALING THE AUTOPED OPERATOR	8
IMPORTANT INSTALLATION NOTE	9
I.1 DOOR HANDING	10
I.2 TORXUN RECOMMENDATION FOR THE OPERATOR INSTALLATION	10
I.3 INSTALLATION: LEFTHAND OPERATOR ON HEADERS 4" OR MORE IN HEIGHT	11
I.4 INSTALLATION: RIGHTHAND OPERATOR ON HEADERS 4" OR MORE IN HEIGHT	12
I.5 INSTALLATION: SWING ARM ASSEMBLY	13
I.6 INSTALLATION: ROCKER ARM SWITCH (OR OPTIONAL ON/OFF KEY SWITCH)	16
I.7 INSTALLATION: ADDITIONAL ACTIVATION AND SAFETY CONTROL DEVICES	18
I.8 CONNECT THE OPERATOR TO 115 VAC POWER SUPPLY	19
SECTION II. PROGRAMMING	20
IMPORTANT PROGRAMMING NOTE	21
II.1 PROGRAMMING FLOW – GUIDE CHART	21
II.2 PROGRAMMING SEQUENCE FOR SINGLE DOOR/GATE OPERATION	22
II.3 PROGRAMMING SEQUENCE FOR DOUBLE DOOR/GATE OPERATION	25
II.4 ADDITIONAL PROGRAMMING OPTIONS	27
II.5 FINAL ADJUSTMENTS AND ANSI 156.19 COMPLIANCE	27
II.6 REATTACH CONTROL BOX COVER AND OPERATOR FRONT COVER.....	28

SECTION III. PRODUCT WARRANTY AND REGISTRATION..... 29
III.1 TORXUN LIMITED WARRANTY 30
III.2 PRODUCT REGISTRATION 31

AUTOPEDED OPERATOR PARTS AND COMPONENTS



TPU.0.0333.0.042821

Item	Description	Qty
1	Enclosure - Front Cover	1
2	Enclosure - Rear Cover (Chassis)	1
3	Control Unit Cover - Front	1
4	Control Unit Cover - Rear	1
5	Control Unit	1
6	Motor-Gearbox Assembly	1 set
7	Mounting Plate	1 set
8	Spindle Extension; 20MM	1
9	Swing Arm Assembly (factory assembled: Lever Arm, Push Arm and Arm Shoe)	1
10	Rocker Switch Kit	1 set
11	Paper Mounting Template	1
12	Conduit Adapter Kit	1 set

SECTION I

INSTALLING THE AUTOPED OPERATOR

IMPORTANT INSTALLATION NOTE

THE AUTOPED OPERATOR CAN BE USED IN A LEFTHAND OR RIGHTHAND, PUSH OR PULL DOOR/GATE SYSTEM APPLICATION WITHOUT NEED FOR CONVERSION ADAPTER OR MODIFICATION

TO CHANGE THE HANDING OF OPERATOR:

- FLIP THE MOTOR-DRIVE ASSEMBLY CLOCKWISE OR COUNTER-CLOCKWISE BEFORE MOUNTING TO CHASSIS; Fig 1
- CHASSIS IS NEUTRAL, ORIENTATION IS THE SAME FOR LEFT OR RIGHT HAND INSTALLATION
- LEFTHAND OPERATOR INSTALLATION: CONTROL BOX UNIT IS AT LEFT OF GEAR BOX
- RIGHTHAND OPERATOR INSTALLATION: CONTROL BOX UNIT IS AT RIGHT OF GEAR BOX

Fig I.1 CHANGING OPERATOR INSTALLATION: LEFTHAND TO RIGHTHAND OR VICE VERSA

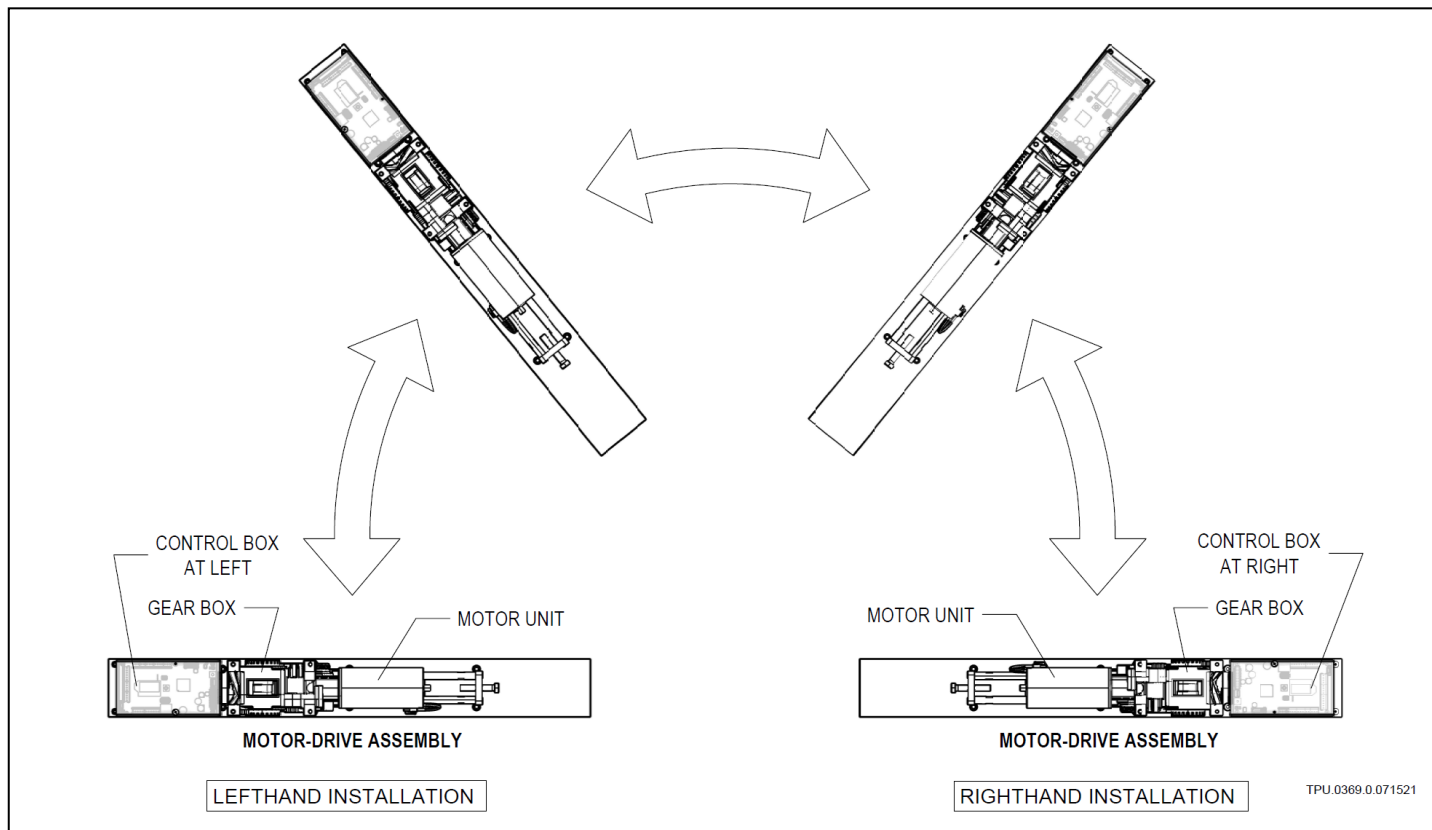

I.1 DOOR HANDING

I.1a Door Handing Definition

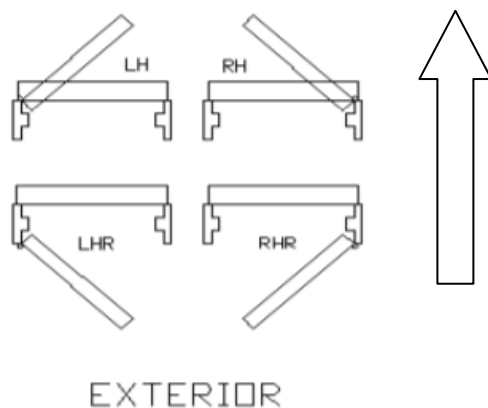

LH: Left Hand -> typically with a pull arm

RH: Right Hand -> typically with a pull arm

LHR: Left Hand Reverse -> typically with a push arm

RHR: Right Hand Reverse -> typically with a push arm

I.1b Push Application – Same Drive Unit for LHR and RHR

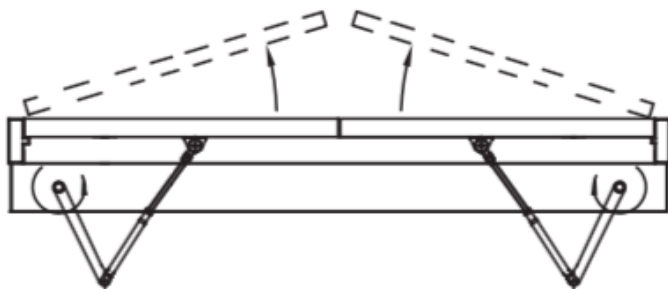

I.1c Pull Application – Same Drive Unit for LH and RH

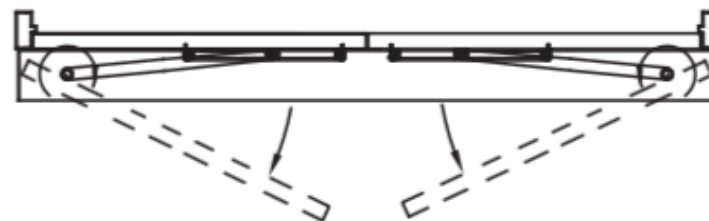

I.2 TORXUN RECOMMENDATION FOR OPERATOR INSTALLATION



1. TORXUN recommends installing the AUTOPED on Door/Gate **headers measuring four inches (4”) OR MORE in height.**
2. For installation on headers less than four inches (4”) in height, TORXUN requires the use of the AUTOPED StiffenerPlate or equivalent to add rigidity to the installation of the operator; refer to **AUTOPED/ AUTOPED OPERATOR APPENDIX MANUAL, Sections I.2 and I.3**

I.3 INSTALLATION: LEFTHAND OPERATOR

STEP 1 Use LH side of Mounting Template

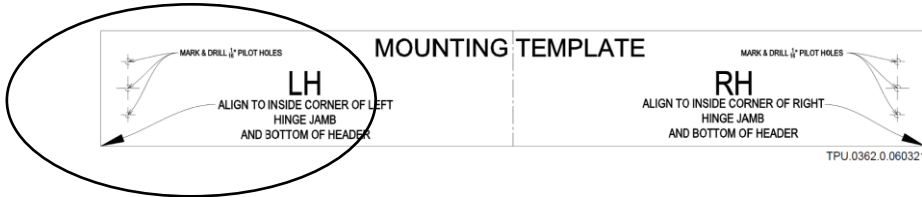

STEP 2 Align arrow to inside corner of left hinge jamb and bottom of header

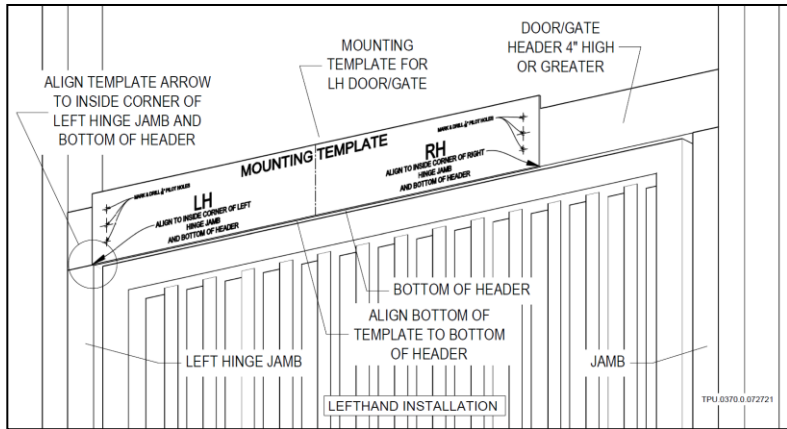

STEP 3 Center-punch mounting holes through Template

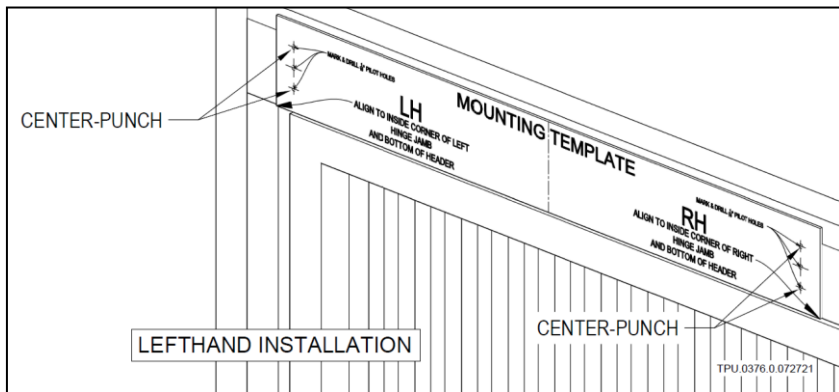

STEP 4 Drill 1/16" pilot holes on header through Template

STEP 5 Mount¹ operator Chassis directly to header

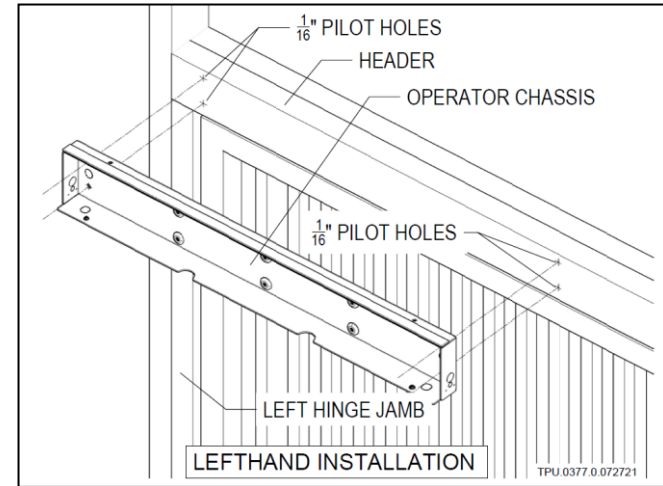

STEP 6 Mount² Motor-Drive assembly to operator Chassis

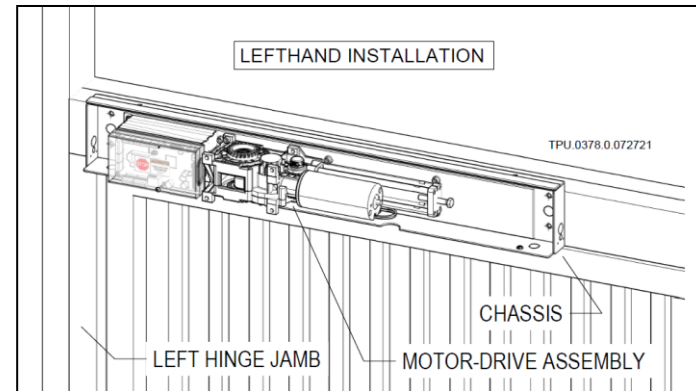

¹ Type, size and material of fastener by installer

² Use Screw M6 x 1.0 x 12 included in kit

I.4 INSTALLATION: RIGHTHAND OPERATOR

STEP 1 Use RH side of Mounting Template

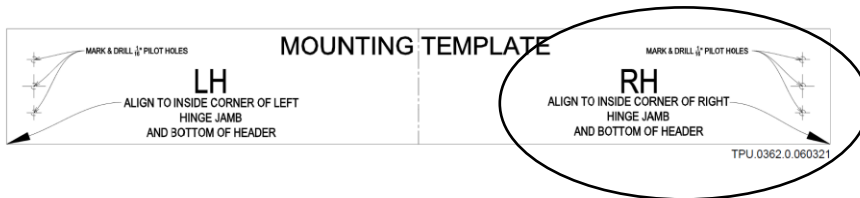

STEP 2 Align arrow to inside corner of right hinge jamb and bottom of header

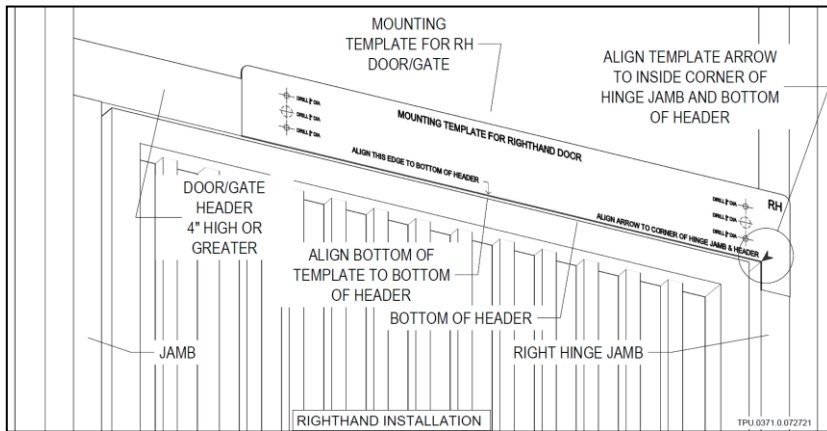

STEP 3 Center-punch mounting holes through Template

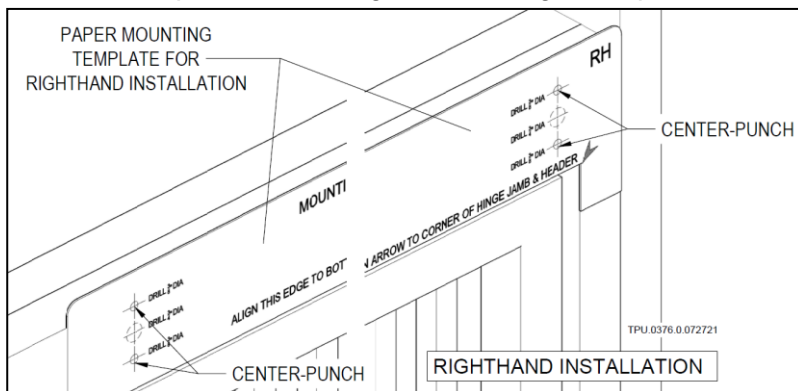

STEP 4 Drill 1/16" pilot holes on header through Template

STEP 5 Mount³ operator Chassis directly to header

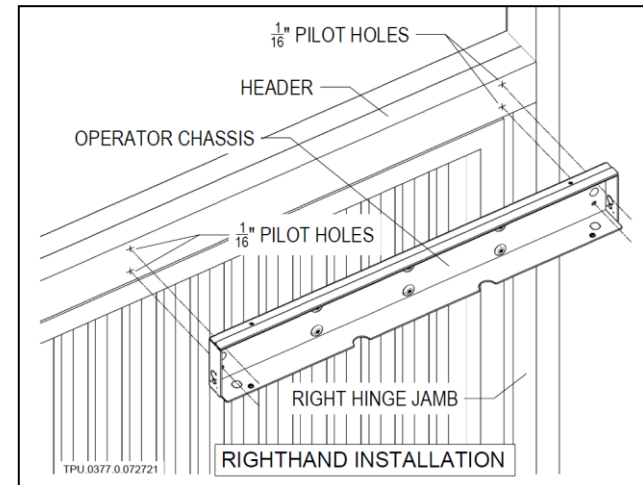

STEP 6 Mount⁴ Motor-Drive assembly to operator Chassis

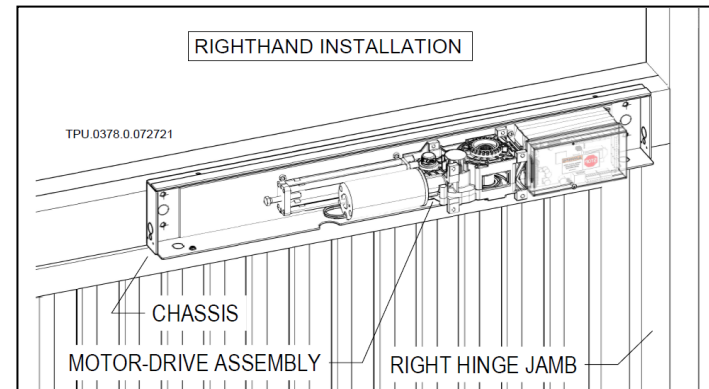

³ Type, size and material of fastener by installer

⁴ Use Screw M6 x 1.0 x 12 included in kit

I.5 INSTALLATION: SWING ARM ASSEMBLY

STEP 1 Assemble the Swing Arm

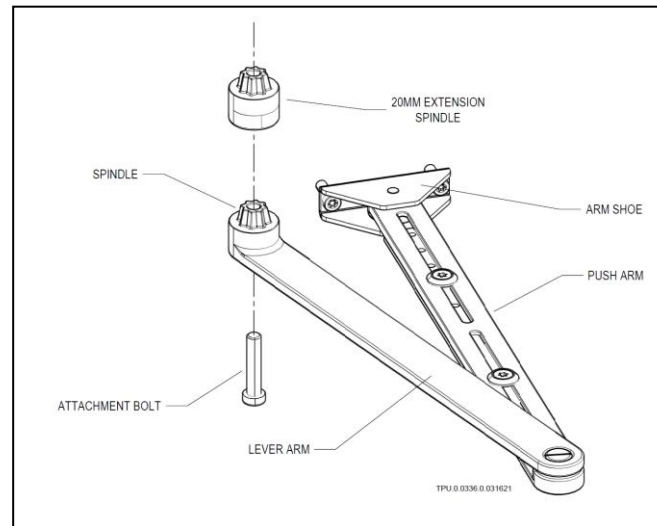

STEP 2 Insert Swing Arm assembly with 20MM standard Extension Spindle to the Operator Gear Box

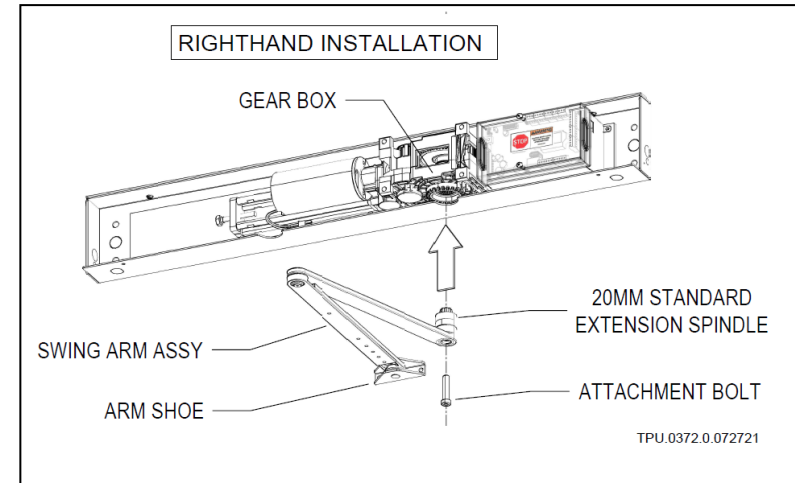
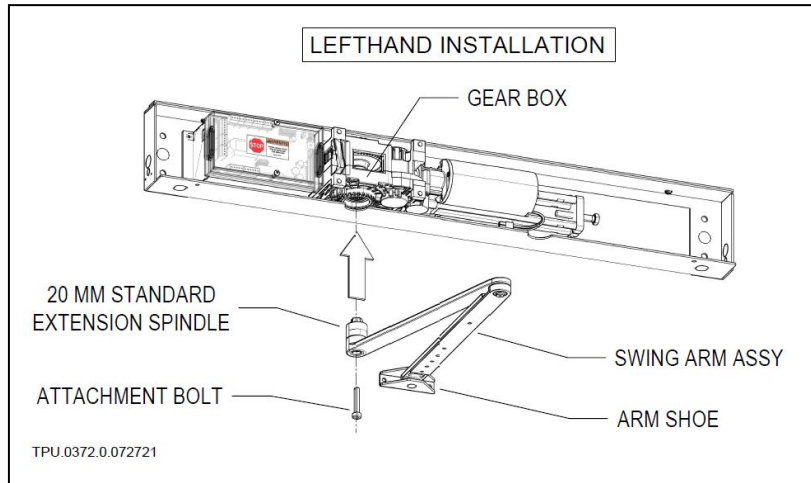

Note: A 30mm Spindle Extension is included in an optional kit (P/N M10S-0018), if needed, it may be used instead of the 20mm to lower further the Swing Arm assembly to have a wider clearance between bottom of AUTOPED operator and top of Arm Shoe

STEP 3 Sit the Arm Shoe squarely on the face of the Door/Gate frame (or panel)

STEP 4 For Lefthand installations, place centerline of Arm Shoe 4" to the right of the centerline of spindle
For Righthand installations, place centerline of Arm Shoe 4" to the left of the centerline of spindle

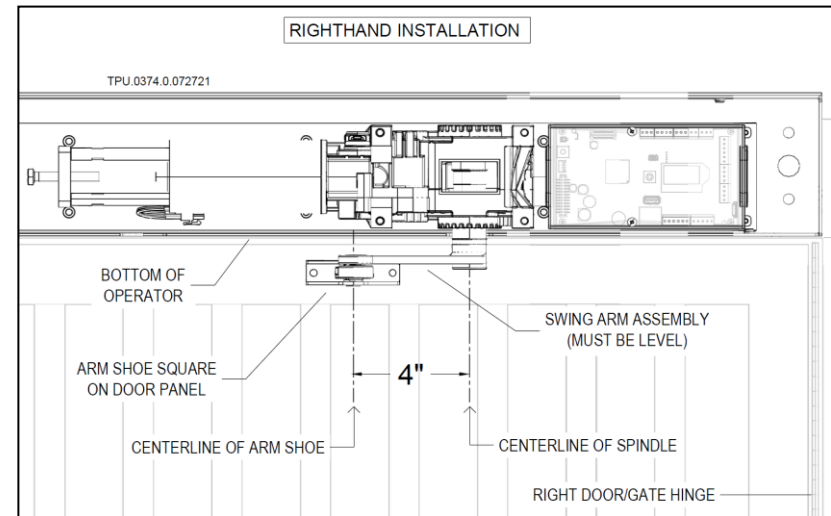
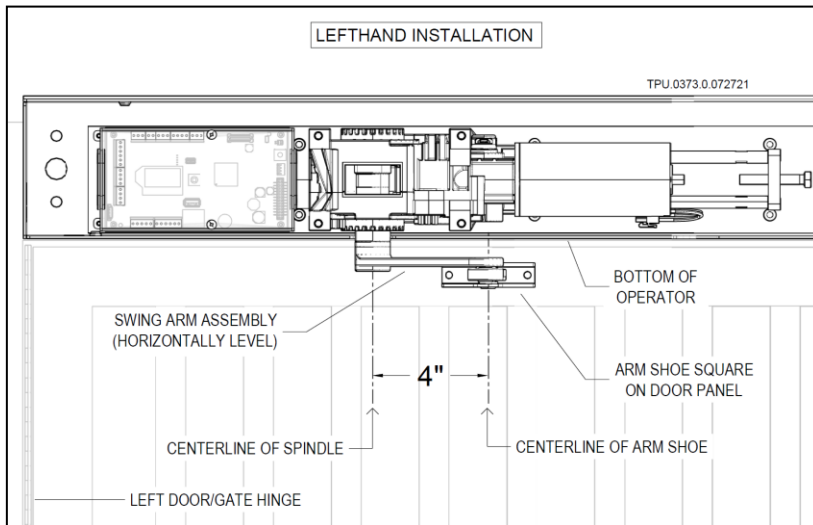

Note: Make sure the Swing Arm is inserted to the Gear Box snugly and installed level

STEP 5 Use Arm Shoe holes as template; mark the holes and center-punch through Door/Gate frame (or panel)

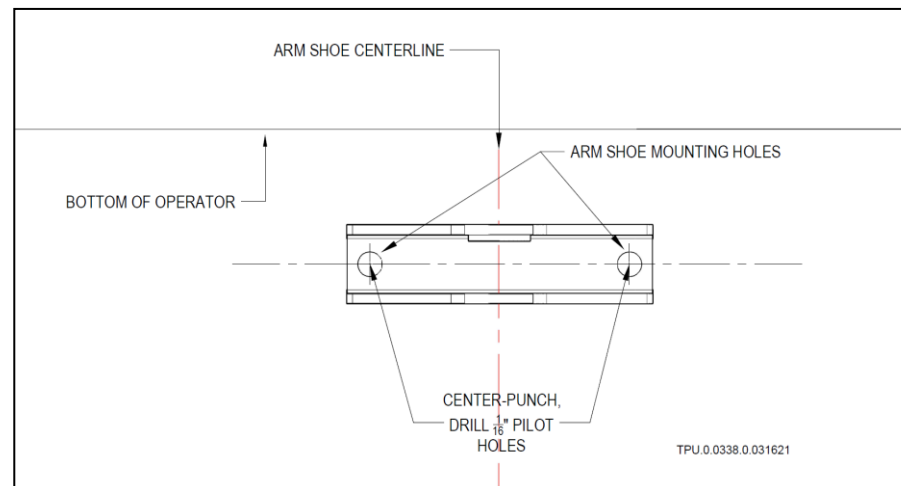

STEP 6 Drill 1/16" pilot holes on the center marks

STEP 7 Use the appropriate fasteners⁵ to mount the Arm Shoe on the Door/Gate panel

STEP 8 Loosen lock screws on Push Arm assembly; adjust length of arm to form about 90° between Push Arm and Door/Gate panel

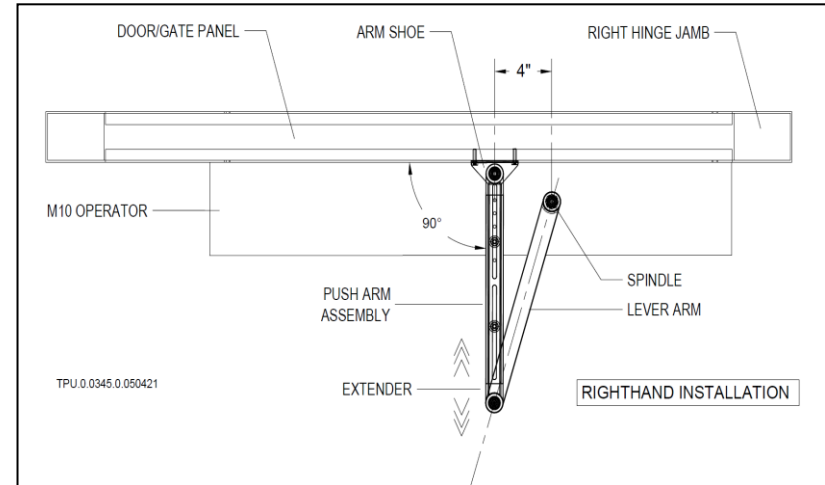
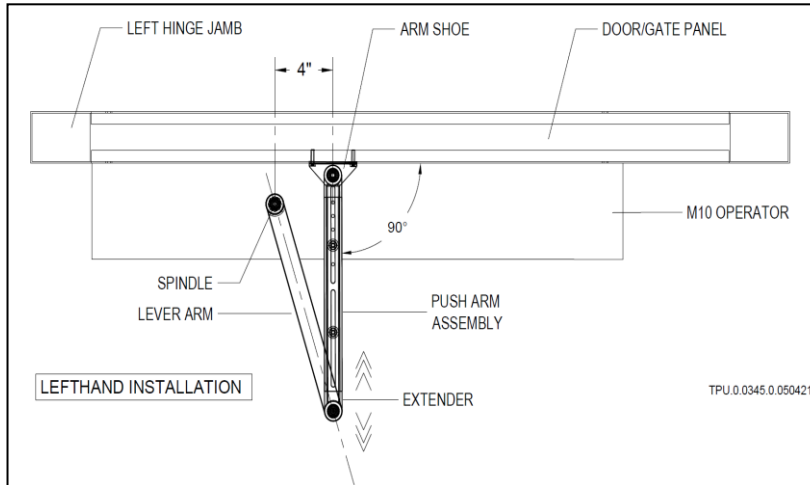

STEP 10 Tighten all screws and fasteners.

⁵ Type, size and material of fasteners by installer
Autoped/ M10 Installation Manual rev 1.0 (102121)

I.6 INSTALLATION: ROCKER ARM SWITCH (OR OPTIONAL ON/OFF KEY SWITCH*)

Provided with your operator is an emergency break-contact switch (Rocker Arm Switch) that cuts-off system inputs o the operator. When the switch is activated, system will go in to an emergency shut down mode; operator will still have electrical power for resetting.

NOTE: The Rocker Arm Switch may be installed on the bottom left or right of the AUTOPED operator; knockouts are provided at both ends.

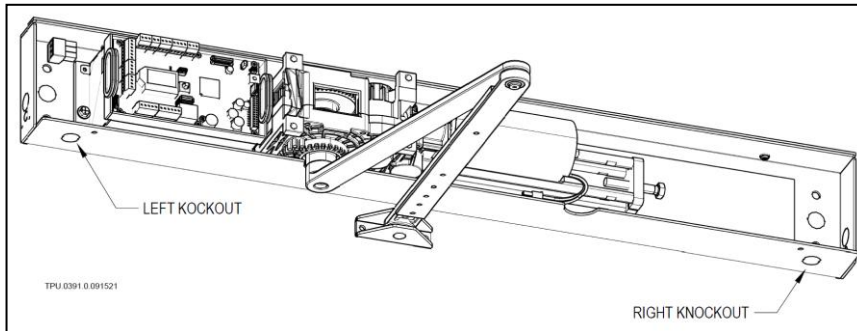

STEP 1 Choose and punch out one knockout at the bottom of the AUTOPED chassis (Note: The following illustrations show the use of the left knockout)

STEP 2 Feed the two switch wires through the knockout then attach the switch to the chassis

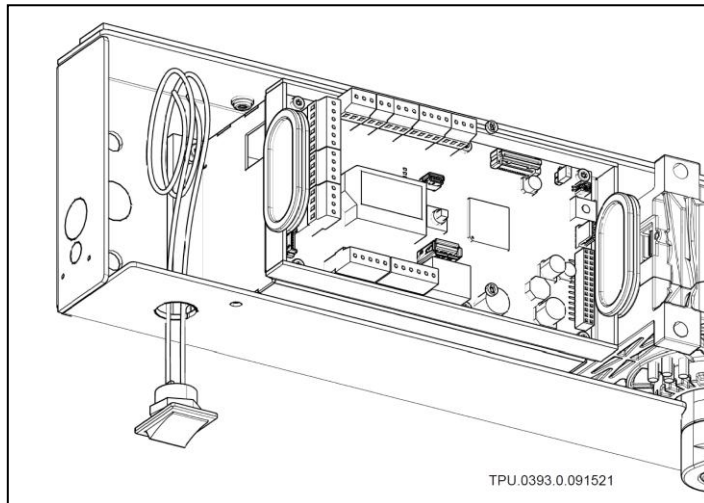

STEP 3 Locate terminal Block X104 as shown in the figure below, and remove jumper across

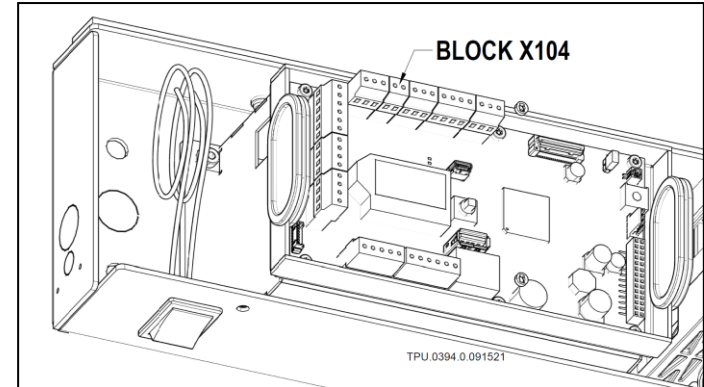

STEP 4 Feed the switch wires through the rubber grommet on the control unit and connect to Block X104

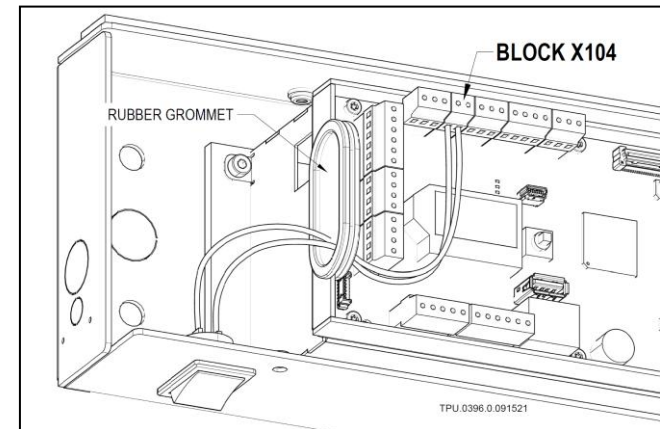

STEP 5 Refer to the Appendix Manual to program the switch function; refer to **Section IV.7 EMY-IN**

* **ON/OFF KEY SWITCH** (P/N LD5172-210-094-0214)

An alternate to the **ROCKER ARM Switch** is the **ON/OFF KEY Switch**, an optional item that can be purchase from TORXUN as replacement of the Rocker Arm switch for a secured type of cut-off switch.

Install the Key Switch in the same manner the Rocker Arm Switch is installed; see above instructions STEP 1 to STEP 5.

Fig 1.6 On/Off Key Switch



I.7 INSTALLATION: ADDITIONAL ACTIVATION AND SAFETY CONTROL DEVICE

Pull the wires for any additional control devices, locking devices or other monitoring elements. Connect the wires for any additional devices to the appropriate terminals on the control board. You will find wiring diagrams for additional device hook ups in Appendix Section VI, pg. A-32.

To program additional devices, see Appendix Section IV (menus and programming) on pg. A-17.

Additional devices might include:

I.7.a Hard wired or radio frequency activation controls (See Appendix VI.1 and VI.2 for wiring schematics)

I.7.b Lock hardware (See Appendix VI.3 and VI.4 for wiring schematics)

I.7.c Access Control (secured activation) devices (fire alarm, card reader/keypad, etc.) (See Appendix VI.5 for wiring schematics)

I.7.d Double Door or Interlock/Sally Port installation (See Appendix VI.6 for wiring schematics)

I.8 CONNECT THE OPERATOR TO 115 VAC POWER SUPPLY (AUTOPEd internal wiring is prewired at the factory)

- The Chassis has Wire Access Holes for 115 VAC power

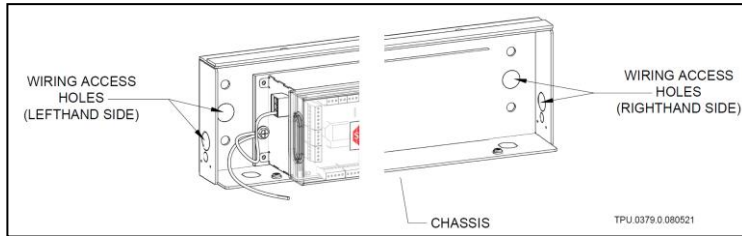

STEP 1 Shut off 115 VAC power to Operator

STEP 2 Pull out Power Connector from Control Unit

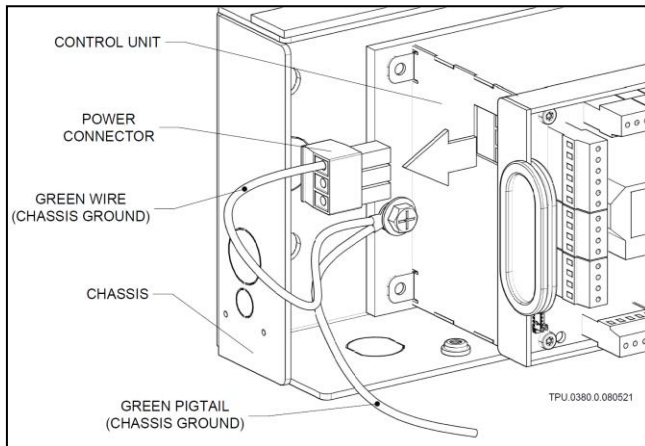

STEP 3 Feed the 115 VAC line through a Wire Access Hole

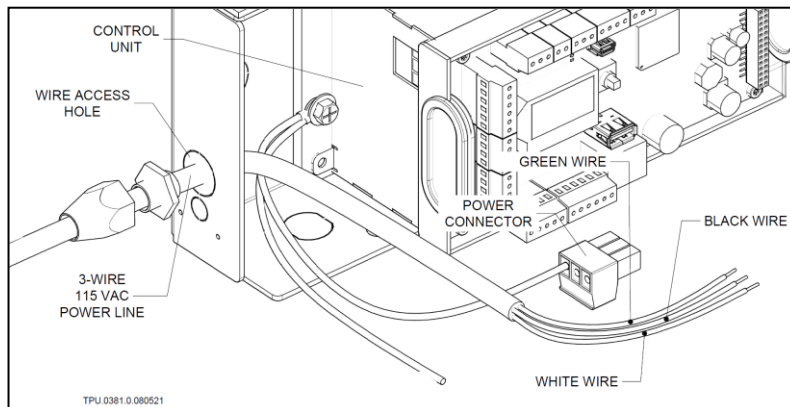

STEP 4 Connect the 115 VAC wires to the Power Connector

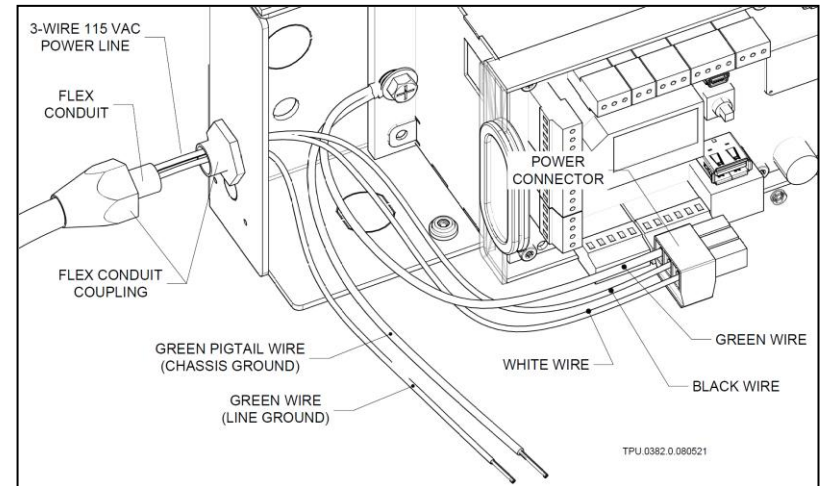

STEP 5 Use wire nut to connect Line Ground and Green Pigtail wires together

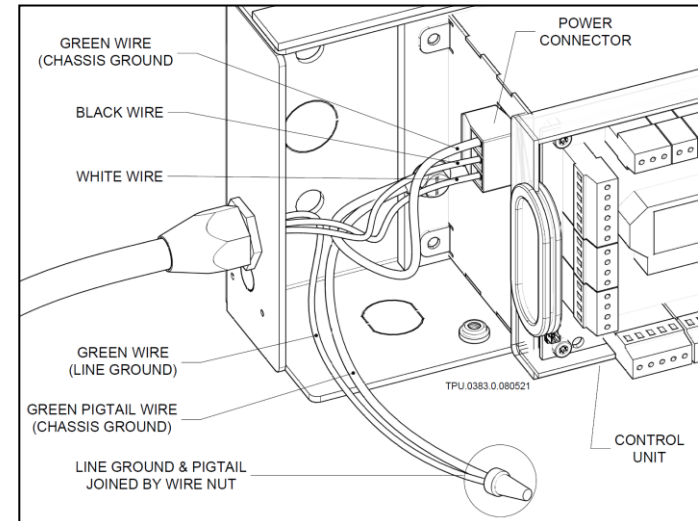

STEP 6 Plug Power Connector back to Control Unit; turn AC power back on

SECTION II

PROGRAMMING

IMPORTANT PROGRAMMING NOTE

II.1 PROGRAMMING FLOW GUIDE CHART

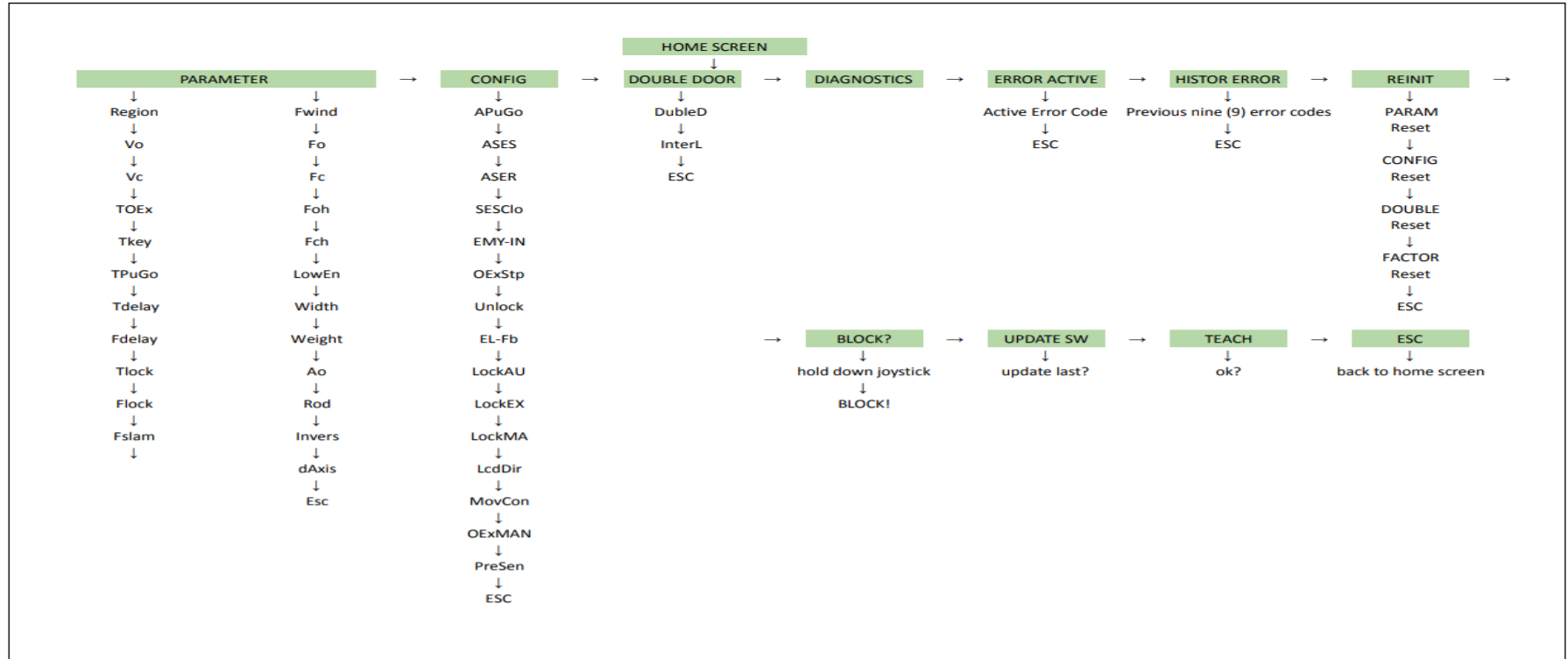

The two most common “error” codes encountered when programming are E10 and E11.

E10

The E10 code simply indicates that the operator needs to be run through a TEACH cycle. Enter the menu and scroll down to “Teach.” Push the joystick in and confirm “yes” by pushing in again. The operator will perform a countdown, beep and run a TEACH cycle of the gate.

E11

The E11 code indicates that the gate must complete on full cycle of motion to confirm the previous TEACH cycle. Give the gate an activation command to perform this cycle and the E11 will be resolved.

Anytime an item in the “Parameter” menu is changed the E10 code will appear and a Teach cycle is necessary.

II.2 PROGRAMMING SEQUENCE FOR SINGLE DOOR/GATE OPERATION

Following are the basic programming steps for the AUTOPED operator. Complete these 12 steps before addressing advanced programming requirements.

⚠ Warning: The default setting of this operator is low energy. It is the responsibility of the installing party to adhere to ANSI A156.19 when completing the installation of the operator. If the operator is to be used as a Full Energy system, then all ANSI A156.10 standards and requirements must be met including but not limited to safeties, entrapment devices, etc. If the desired use of the operator is a Full Energy application, contact the manufacturer prior to installation. ⚠

Once power has been supplied or reconnected to the control unit, indicator lights will flash, and the LCD display will light up with the current software version. The following procedure will get the AUTOPED operational with basic programming. The control unit is password protected! The password is three presses left on the joystick followed by three presses right on the joystick. (←,←,←,→,→,→)

- Locate the LCD display window and the joystick adjacent to it.
- The joystick can be moved in four (4) directions: Up (↑), Down (↓), Left (←), Right (→)

STEP 1: Screen Orientation The first words to appear on the LCD screen are: “Press Down”. The text will alternate between being right side up and upside down. Pressing the joystick in the down (↓) direction will set the screen orientation to the direction of the joystick.

- The downward movement of the joystick is in relation to the installer, not the LCD screen. The screen will react and set itself to orientate to the installer.

STEP 2: Region Selection

- Press the joystick in and then either left or right (←,→) to select “Region USA”

STEP 3: Rod

- Select the appropriate type:
 - STD-PH (standard push arm)
 - SLI-PL (optional slide arm pulling configuration)
 - SLI-PH (optional slide arm pushing configuration)
 - ⚠ WIN-PH, DIR-PH, DIR-PL, OHC-PH, OHC-PL will not be used! ⚠
 - Press the toggle in to select the appropriate arm type

STEP 4: dAxis

- The D Axis is the distance from the chassis mounted to the header to the centerline of the gate leaf hinge. Measure this distance on the door/gate.

- Toggle left and right to get the correct number in inches and press the joystick in to confirm the selection.

STEP 5: Ao

- Ao is the angle of opening.
- The default selection is 95°, toggle left or right to select the desired angle of opening then press the joystick in to confirm the selection.

STEP 6: LowEn

- This is the type of function the operator will work as. The default is “LowEn on”.
- Keep the operator in LowEn on and press the joystick in to confirm the selection.
- The operator is intended to be used in LowEn mode and ANSI 156.19 standards
- (Triangle Warning) If a full energy application is desired, it is the responsibility of the installer to make sure that all safeties, entrapment devices, and overall installation is up to ANSI A156.10 standards and requirements. Contact the manufacturer before using the operator in a full energy application

STEP 7: Width

- Measure the gate leaf from outside edge to outside edge and use the toggle left or right to select the correct width in inches of the gate leaf. Press the joystick in to confirm the selection.

STEP 8: Weight

- Calculate the approximate weight of the gate leaf.
- Use the joystick either left or right to select the approximate weight in pounds (lbs) of the gate leaf. Press the joystick in to confirm the selection.

STEP 9: Vo

- Vo is the velocity of the opening; this controls the speed at which the gate opens.
- The default setting is 6, use the joystick left and right to select the desired speed. Press the joystick in to confirm the selection.
 - a. In LowEn: ON mode, the selection maximum is 9.
 - b. In LowEn: Off mode, the selection maximum is 14.
- ⚠ TORXUN recommends setting Vo between 1-3 for initial set up. Once the operation of the gate is confirmed, then the desired speed can be finalized in compliance with ANSI 156.19. ⚠

STEP 10: Vc

- Vc is the Velocity of the closing, this controls the speed at which the gate closes.
- Default is set to 6, use the joystick left and right to select the desired speed. Press the joystick in to confirm the selection.
 - a. In LowEn: ON mode, the selection maximum is 9

- b. In LowEn: Off mode, the selection maximum is 14
- ⚠ TORXUN recommends setting Vc between 1-3 for the initial set up. Once the operation of the gate is confirmed, then the desired speed can be finalized in compliance with ANSI 156.19. ⚠

STEP 11: Invers

- Using the joystick left and right, set Invers to “OFF”. Press the joystick in to confirm the selection.
- Invers refers to configuring the door/gate to open when power is lost. In such rare applications the gate will default (spring) to open and operate to close.

⚠ ATTENTION: At this point, clear the area of any persons or objects in the path of the gate to avoid injuries or damages. Proceed to the next step once the path of the gate is clear. ⚠

STEP 12: Teach

- Press the joystick in to move to the next selection.
- “Teach ok?” will appear on the screen
- Press the joystick in again and you will hear beeping as well as see a ten (10) second countdown on the screen.
- Once the countdown ends, the gate will open, pause, and then close while beeping. If no errors occur, the LCD display will display “Done!” with “E11” underneath it.
- E11 requires the gate leaf to go through one more full Open and Close cycle to confirm the settings.

II.3 PROGRAMMING SEQUENCE FOR DOUBLE DOOR/GATE OPERATION

⚠ Warning: The default setting of this operator is low energy. It is the responsibility of the installing party to adhere to ANSI A156.19 when completing the installation of the operator. If the operator is to be used as a Full Energy system, then all ANSI A156.10 standards and requirements must be met including but not limited to safeties, entrapment devices, etc. If the desired use of the operator is a Full Energy application, contact the manufacturer prior to installation. ⚠

The AUTOPED is capable of being linked to another AUTOPED and run as a double door/gate. In the double gate mode, you will be able to set the timing for the opening of the gate to be the same or separate depending on the requirements of your application. The functions of the double gate mode are, **together**, **staggered**, and **interlock**.

When both doors are running together, any open command to the slave/secondary door will open both the master gate and the slave/secondary gate at the same time. A command to the master gate will open just the master.

II.3.a DOUBLE DOOR

Setting the double door feature.

STEP 1: Using the joystick, scroll through the Parameter menu until you get to **dubleD**

- Using the joystick enter the selection and determine if the operator will be either **Master A** or **Slave A**.
- Activate the Master AUTOPED first.

STEP 2: Wire between Master and Slave/Secondary Operators

- Wire the Master A gate AUTOPED to the Slave/Secondary A AUTOPED. Run the wire between terminal X117 on each control board.(See Appendix VI.6 for wiring schematic)
 - When the CANbus connection is made between the AUTOPED controllers, the master is identified by a small black (m) and the slave by a small black (s) on their respective LCD's.
 - If a CANbus connection does not exist, the master is identified by a small white (m) and the slave by a small white (s).

STEP 3: Vo

- Using the joystick, toggle down to VO (opening speed) and set the desired opening speed
 - Each operator can be set independent from each other. It is possible to have two gate leaves move at different speeds if deemed necessary. For example, the master can have a VO of 5 while the slave has a VO of 7.

STEP 4: AoSeq

- Using the joystick in the Master Operator, toggle down to **AoSeq**.
 - AoSeq is the delay angle of the Master before the Slave/Secondary begins its opening sequence.

- For example, if you set AoSeq to 20° then the slave operator's gate will wait until the master gate breaks the 20° mark then it will start to open.

STEP 5: TDelay

- If an electric lock is installed on the gate system, the selection **TDelay** will function the same way that it would in the normal programming sequence and adjust the amount of time that the gate delays before moving to allow time for the lock to release. For this set up refer to Appendix IV.6 TDelay.

STEP 6: AcSeq

- Using the joystick on the Slave operator, select **AcSeq**. AcSeq is the delay for the master closing sequence. The default AcSeq setting is 0 degrees. This will work the same way that AoSeq does, allowing a set degree of closure to happen before the master gate starts movement.

II.3.b INTERLOCK/ SALLY PORT/ AIRLOCK

If the gates are interlocking (two gates spaced apart from each other and work together so they are not open at the same time in secure or air lock applications), you will adjust the timing so that one of the gates can either start to open or start to close before the other to the desired coordinated function. When gate A gets an open command, it will block out any inputs to Gate B until Gate A is fully closed. The same is true for gate B. When Gate A is opened, Gate B will not be able to open until Gate A is fully closed.

STEP 1: Wire between Gate A and Gate B Operators

- Wire the Gate A AUTOPEd to the Gate B AUTOPEd. Run the wire between terminal X117 on each control board.(See Appendix VI.6 for wiring schematic)

STEP 2: InterL

- Make sure that **doubleD** is off in the Programming menu.
- Using the joystick toggle down to InterL
 - Set one control unit to side A and the other to side B
- With the two control units set to interlock A and B respectively, they will work independent of each other but not allow input commands to be activated on one gate until the other has completed its cycle.

II.4 ADDITIONAL PROGRAMMING OPTIONS

Before completing the installation, install any additional hardware or make further programming adjustments. These may include:

II.4.a **Push and Go** (when the gate is pushed open a programmable set of degrees, the AUTOPED will take over and open the gate the rest of the way) (See Appendix IV.6 **APuGO** in the Configuration Menu).

II.4.b **Positive Stop** (a mechanical option which prevents the gate from being forced beyond 110 degrees to protect the AUTOPED operator) (See Appendix Section II).

II.4.c **Closing Spring Preload** (adjust the pressure of the door/gate closure to overcome the gate slamming or not fully latching) (See Appendix Section III)

II.5 FINAL ADJUSTMENTS and ANSI 156.19 COMPLIANCE STEPS

Make final adjustments to the controller programming and gate operation.

ANSI 156.19 is a safety standard that protects pedestrians when using a low energy automatic door/gate. The AUTOPED is designed so that each installation can comply with this standard.



IMPORTANT

It is the responsibility of the installer to adjust the AUTOPED so that the gate operates in compliance with ANSI 156.19. Each gate is different so adjustments must be made on a gate-by-gate basis. Refer to the ANSI 156.19 standards for the tables that prescribe:

- The **speed/velocity** of the opening and closing of gate being installed based on its width and weight. Speed is adjusted in the **Vo** and **Vc** settings in the Parameters menu.
- The **force** of the gate when opening and closing. Force is adjusted in the **Fo** and **Fc** settings in the Parameters menu.
- Use the Door Pressure Gauge tool to properly calibrate the force (pressure) of the opening and closing of the gate panel; Fig 11.5
- Signage – Attach signage(s) to Door/Gate and activation switches as specified by ANSI 156.19

Fig 11.5 Door Pressure Gauge Tool (refer to Vendor's Instructions on use)

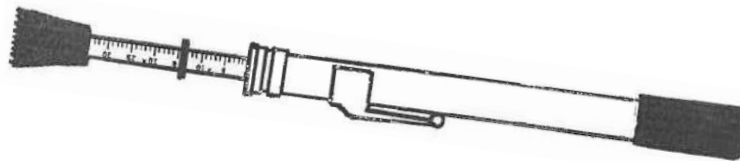

II.6 REATTACH THE CONTROL BOX AND OPERATOR FRONT COVER

II.6.a REATTACH PLASTIC COVER OF CONTROL BOX

After the unit has been cycled a few times and your ANSI checklist has been completed, reattach the plastic cover onto the control unit. Align the gaskets into the cut outs so that they sit flush. Tighten the two provided screws into the threaded sections of the control board. Give the cover a slight tug to make sure that it is secured properly. ⚠ Do not over tighten the cover. ⚠ Make sure that the grommets are completely seated in the cut outs on both ends and sealed properly within the groove.

II.6.b REATTACH OPERATOR FRONT COVER

There are two knock outs on the Front Cover that will correspond with the arm coming from the gearbox. Remove the appropriate knock out for the location of the arm and slide the front cover onto the operator. Secure the front cover to the chassis with the four (4) thumb screws. Tighten the thumb screws by hand until the front cover is secured to the chassis.

CONGRATULATIONS, YOUR INSTALLATION IS NOW COMPLETE!

SECTION III
PRODUCT WARRANTY
And
REGISTRATION

III.1. TORXUN LIMITED WARRANTY

To the original purchaser only: TORXUN Vehicle Access Technologies, (hereafter referred to as TORXUN) warrants, for one (1) years from the date of invoice, the gate operator systems and other related systems and equipment manufactured by, and distributed by TORXUN, to be free from defects in material and workmanship under normal use and service for which it was intended provided it has been properly installed and operated. TORXUN's obligations under this warranty shall be limited to the repair or exchange of any part or parts manufactured by and distributed by TORXUN. Defective products must be returned to TORXUN, freight prepaid by purchaser, within the warranty period. Items returned will be repaired or replaced, at TORXUN's option, upon an examination of the product by TORXUN, which discloses, to the satisfaction of TORXUN, that the item is defective. TORXUN will return the warranted item freight prepaid. The products manufactured by TORXUN and distributed by TORXUN are not warranted to meet the specific requirements, if any, of safety codes of any state, municipality, or other jurisdiction, and TORXUN does not assume any risk or liability whatsoever resulting from the use thereof, whether used singly or in combination with other machines or apparatus.

Any products and parts not manufactured by TORXUN and distributed by TORXUN, will carry only the warranty, if any, of the manufacturer. This warranty shall not apply to any products or parts thereof which have been repaired or altered, without TORXUN's written consent, outside of TORXUN's workshop, or altered in any way so as, in the judgment of TORXUN, to affect adversely the stability or reliability of the product(s) or has been subject to misuse, negligence or accident, or has not been operated in accordance with TORXUN's instructions or has been operated under conditions more severe than, or otherwise exceeding, those set forth in the specifications for such product(s). TORXUN shall not be liable for any loss or damage whatsoever resulting, directly or indirectly, from the use or loss of use of the product(s). Without limiting the foregoing, this exclusion from liability embraces a purchaser's expenses for downtime or for making up downtime, damages for which the purchaser may be liable to other persons, damages to property, and injury to or death of any persons. TORXUN neither assumes nor authorizes any person to assume for them any other liability in connection with the sale or use of the products of TORXUN. The warranty herein- above set forth shall not be deemed to cover maintenance parts, including, but not limited to, hydraulic oil, filters, batteries, or the like. No agreement to replace or repair shall constitute an admission by TORXUN of any legal responsibility to effect such replacement, to make such repair, or otherwise. This limited warranty extends only to wholesale customers who buy directly through TORXUN's normal distribution channels. TORXUN does not warrant its products to end consumers. Consumers must inquire from their selling dealer as to the nature and extent of that dealer's warranty, if any.

This warranty is expressly in lieu of all other warranties expressed or implied including the warranties of merchantability and fitness for use. This warranty shall not apply to products or any part thereof which have been subject to accident, negligence, alteration, abuse, or misuse or if damage was due to improper installation or use of improper power source, or if damage was caused by fire, flood, lightning, electrical power surge, explosion, wind storm, hail, aircraft or vehicles, vandalism, riot or civil commotion, or acts of God.

III.2 PRODUCT REGISTRATION

Date Today: _____

End User Location & Information

First Name, Last Name	
Company/ Association	
Street Address	
City	
State	
Zip Code	
Telephone	
Email Address	

Product Information

Model Name/ Number	
Serial Number	
Purchase Date	
Installation Date	
Distributor's Name	
Distributor's City	

Installer Information

Company Name	
First Name, Last Name	
Street Address	
City	
State	
Zip Code	
Telephone	
Email Address	

Operator and Gate Use

<input type="checkbox"/> Residential	<input type="checkbox"/> Commercial/ Multi-Family
<input type="checkbox"/> Restricted Access Facility	<input type="checkbox"/> Parking Spaces Inside Garage

Fax or Email this completed form to:

TORXUN™
50 Sloan Court
Tracy, CA 95304
Fax: 888-492-4283
Email: sales@TORXUN.com